

Barstool | Overview

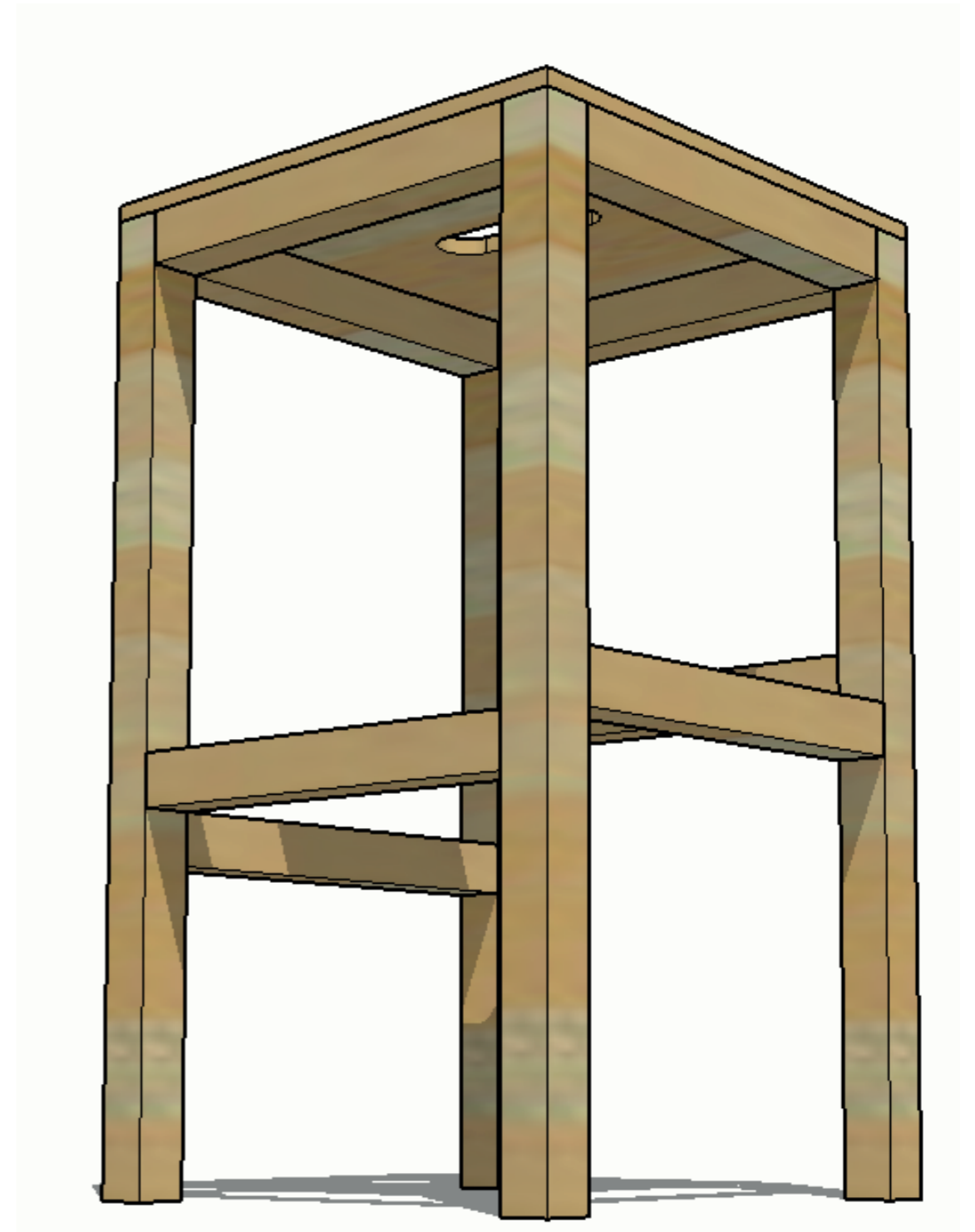

Barstool | Cutting Instructions

1x 1220x2440x12 Ply

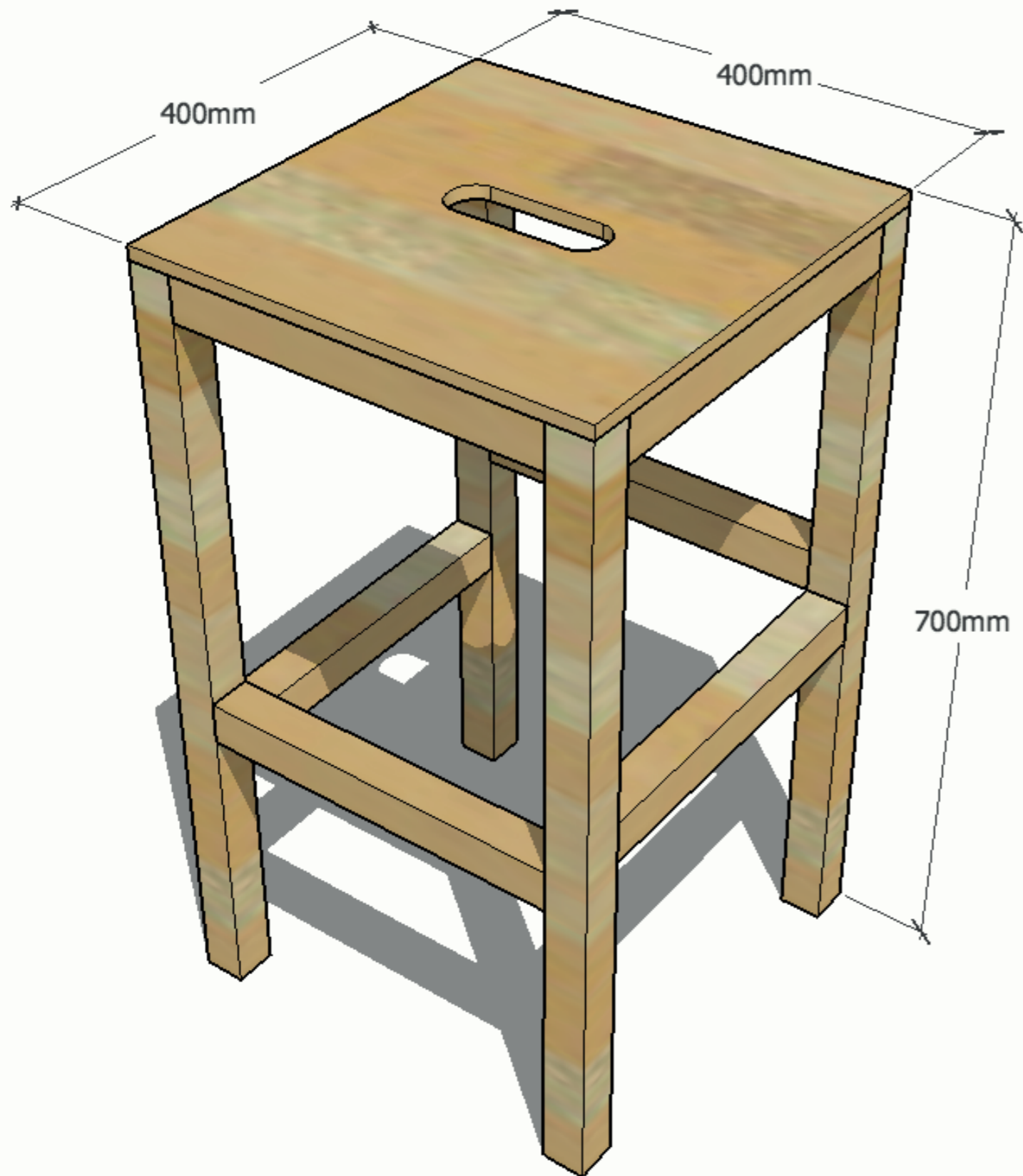
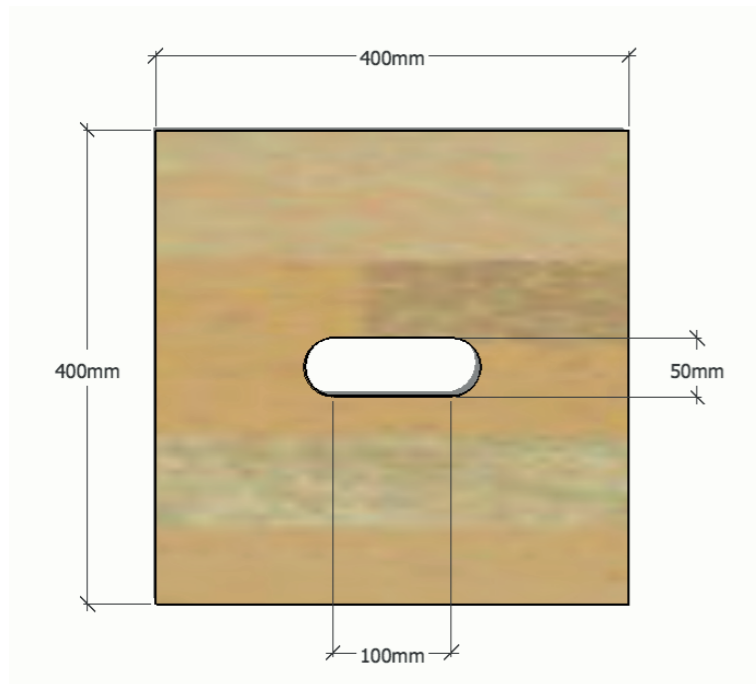

1. Cut out a 400 x 400 piece of ply
2. Use a 50mm hole saw to cut the side of the handle
3. Use a jigsaw to finish the handle cutout

2.5x 38x89x2400 CLS Studding

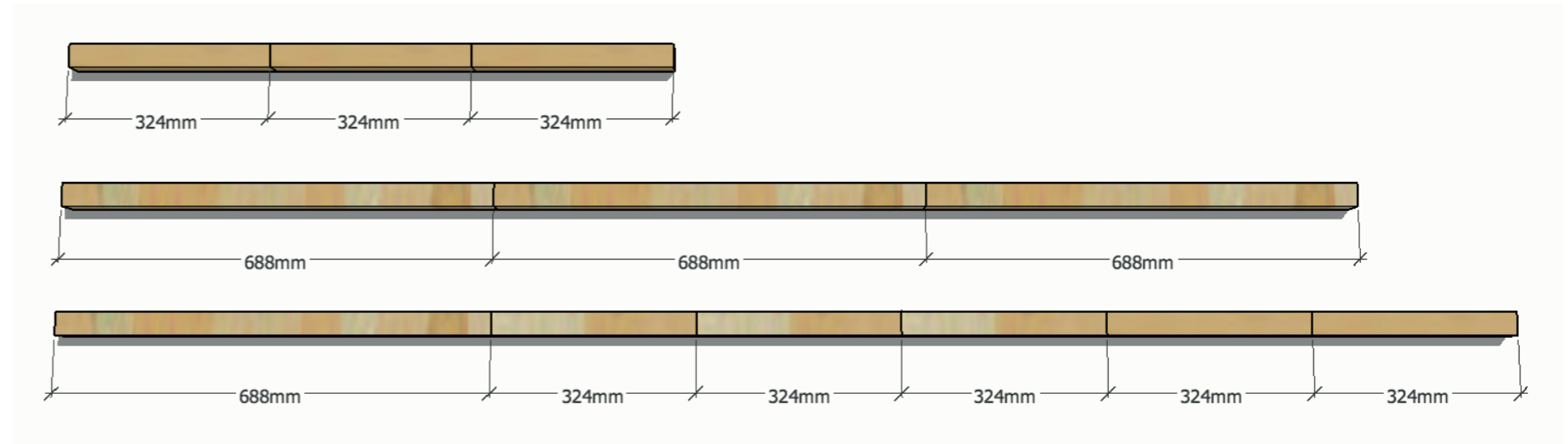

1. Resaw the studding in half - to be left with two 38x43x2400 pieces
2. Thickness plane to 38x38x2400
3. Cut to lengths shown in diagram

Resulting lengths:

4x	688	Legs
8x	324	Stretchers / foot rests

Barstool | Assembly Instructions

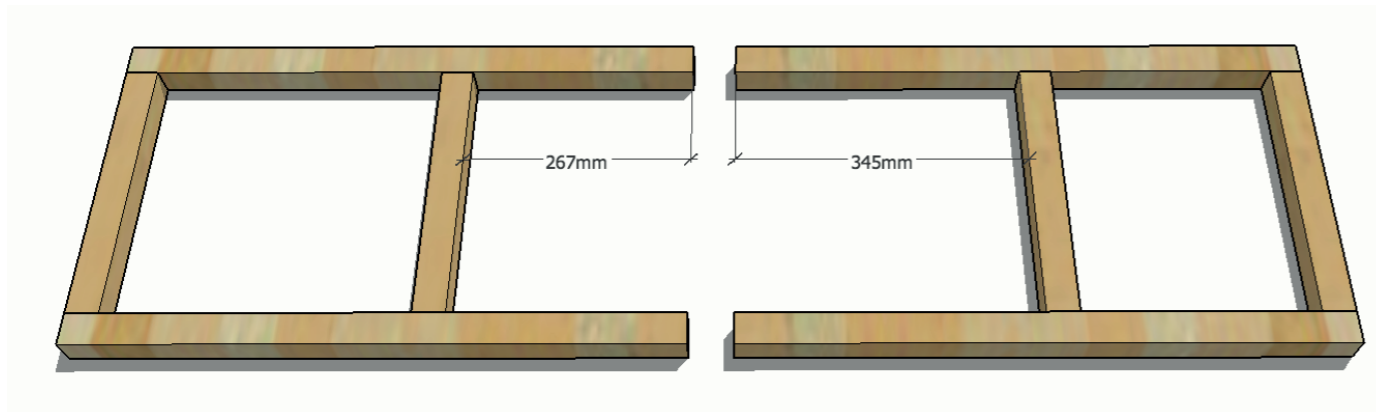

1. Assemble two leg frames (glue + screw)

Notes:

- The foot rests are at different heights!
- Double-check the frames are 400mm wide before finishing

2. Glue and screw the two leg frames to the seat

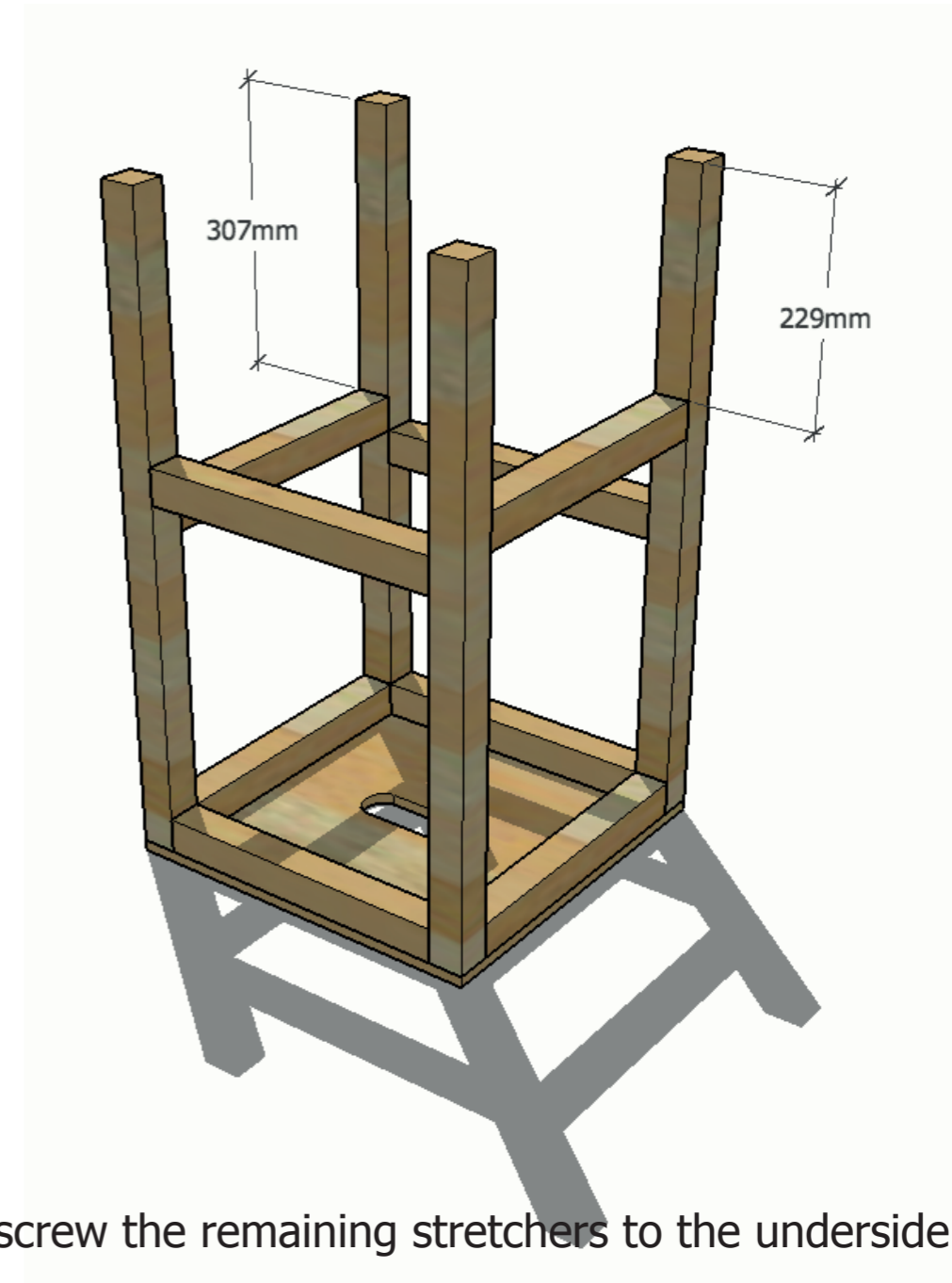
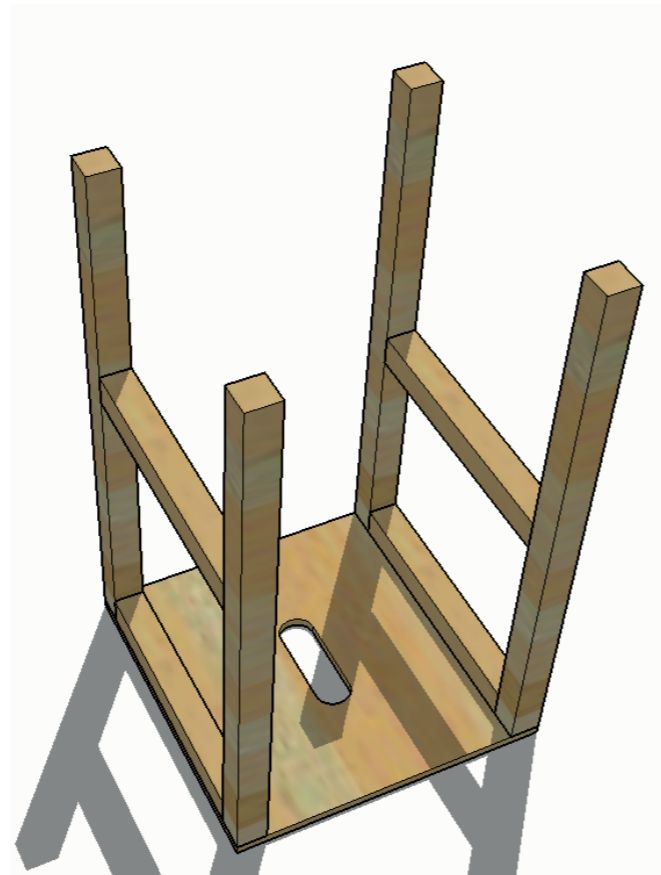

3. Glue and screw the remaining stretchers to the underside of the seat
4. Glue and screw the remaining foot rests - note they are at different heights!
5. Sand and varnish seat top (2 coats)